

Hellwig PRODUCTS.com

559-734-7451 800-367-5480 FAX 559-734-7460

READ THIS INSTRUCTION SHEET COMPLETELY BEFORE STARTING YOUR INSTALLATION

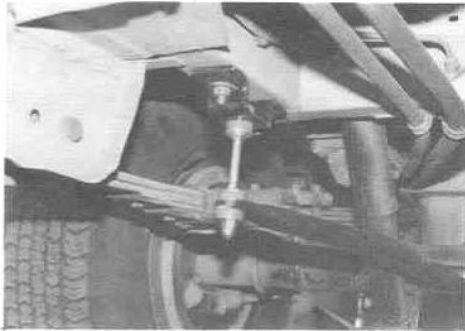

1. (Passenger Side From Front)



1a. (Passenger Side From Under Vehicle)

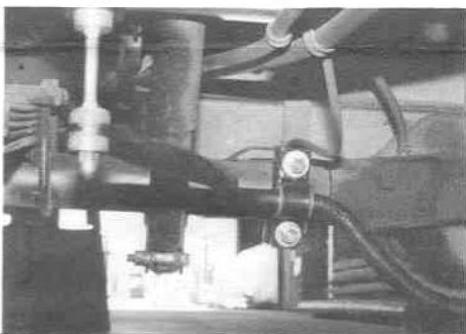

2. (Passenger Side From Front)

TORQUE RATINGS

5/16 Inch	20 ft. lbs.
3/8 Inch	35 ft. lbs.
7/16 Inch	45 ft. lbs.
1/2 Inch	75 ft. lbs.
9/16 Inch	90 ft. lbs.
5/8 Inch	120 ft. lbs.

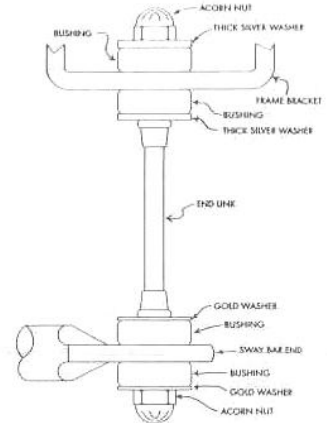

CAUTION
Stay Clear of Brake Lines

THIS UNIT IS DESIGNED TO MOUNT TO THE FRONT OF THE AXLE WITH THE ARMS OF THE BAR FACING FORWARD.

- As per Photo No. 1 locate the 2 offset holes in the bottom of the unibody frame channel forward of the axle, feed the U-bolt into one of the holes and into the frame so the U-bolt comes out the other hole and is inside the frame. Some vans have only one hole, see No. 1a. for instructions on drilling the second hole if needed. If your vehicle has both holes go to No. 2.
- (1a.) The frame brackets have offset holes for the right and left side of the frame. Use the frame bracket as a template to locate the missing hole location in your frame, place the frame bracket against the bottom of the frame so the holes align, the frame bracket will be in line with the frame. Draw a circle inside the hole in the frame bracket and onto the frame with a pencil, put the U-bolt up against the frame and slightly into the existing hole, check to see if your pencil circle lines up with the U-bolt before drilling. Use a 1/2" drill bit. Note the holes should not be straight in line with the frame, the forward most hole should be inboard of the rearward most hole. Place the U-bolt into the frame as per No. 1. See Photo No. 1a.
- Place the frame brackets onto the U-bolts, be sure the frame brackets are in line with the frame or switch sides left to right.
- Place the square spacers onto the U-bolts, and secure the frame bracket to the frame with the flat washers and locknuts provided. Leave loose to allow for the end link installation.
- As per the Diagram, install the end links onto the frame bracket, use the thicker silver flat washers to secure the end link to the frame bracket. Tighten until the acorn nut bottoms, DO NOT OVERTIGHTEN or damage to the acorn nut and bushings will result.
- Raise one side of the bar up at a time and connect the ends of the bar to the end links. Use the gold washers. Be sure the center hump in the bar is downward. Tighten only until the acorn nut bottoms as before. See Photos.
- Place the D-shaped bushings on the back of the bar on each side of the center hump. See Photo No. 2
- As per Photo No. 2 place the round U-bolts over the axle tube in line with the D-bushings, be sure to put the U-bolts under any brake lines or hoses to avoid pinching when tightened.
- Place the saddle bracket onto the U-bolt, place the U-plate over the D-bushing and attach the bar, U-plates, saddle and U-bolts onto the axle with the flat washers and nuts provided. Leave loose to allow for adjustment.
- Rotate the bar and U-bolts on the axle to make the end links as straight up and down as possible and so the arms of the bar are fairly level with the frame.
- Being sure there are no brake lines or hoses under the U-bolts on the axles, torque the U-bolts and frame brackets to the specified rate. Double nut the axle U-bolts.
- Bounce the vehicle checking for clearance on all under carriage components, fuel lines, brake lines, differential etc . . . Test drive the vehicle, readjust as needed. Recheck your installation after one (1) week of driving and ever thirty (30) days thereafter.

ATTENTION INSTALLER: BE SURE THE CUSTOMER RECEIVES THIS INSTRUCTION SHEET, ALL IMPORTANT NOTE CARDS, WARNING CARDS, AND THE WARRANTY FORM.