

**THE CARBURETTER**

- A. Mixing Chamber.
- B. Float " "
- C. " " Lid.
- D. Locking Screw,
- E. Tickler,
- F. Hollow Bolt,
- G. Fibre Washers,
- H. Main Jet,
- I. Needle Jet,

- J. Mixing Chamber Nut.
- K. Throttle Stop Screw.
- L. Stop Lug.
- M. Clamping Screw.
- N. Throttle Valve.
- O. Jet Needle.
- P. Mixing Chamber Top.
- Q. Locking Ring.
- R. Pilot Adjusting Screw.

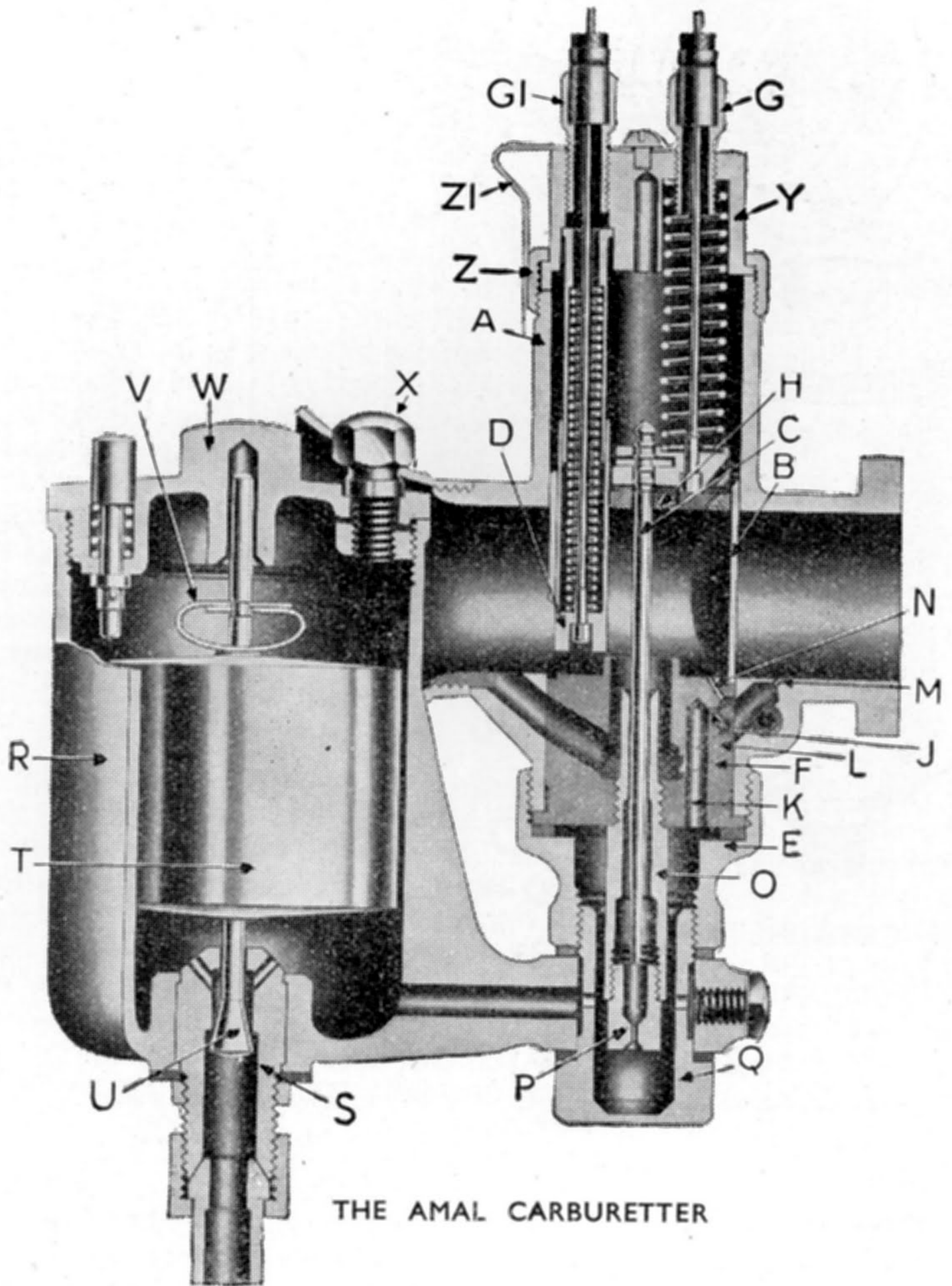

THE AMAL CARBURETTER